

ELPHINSTONE

**69D Dump
Underground
Mining Truck**

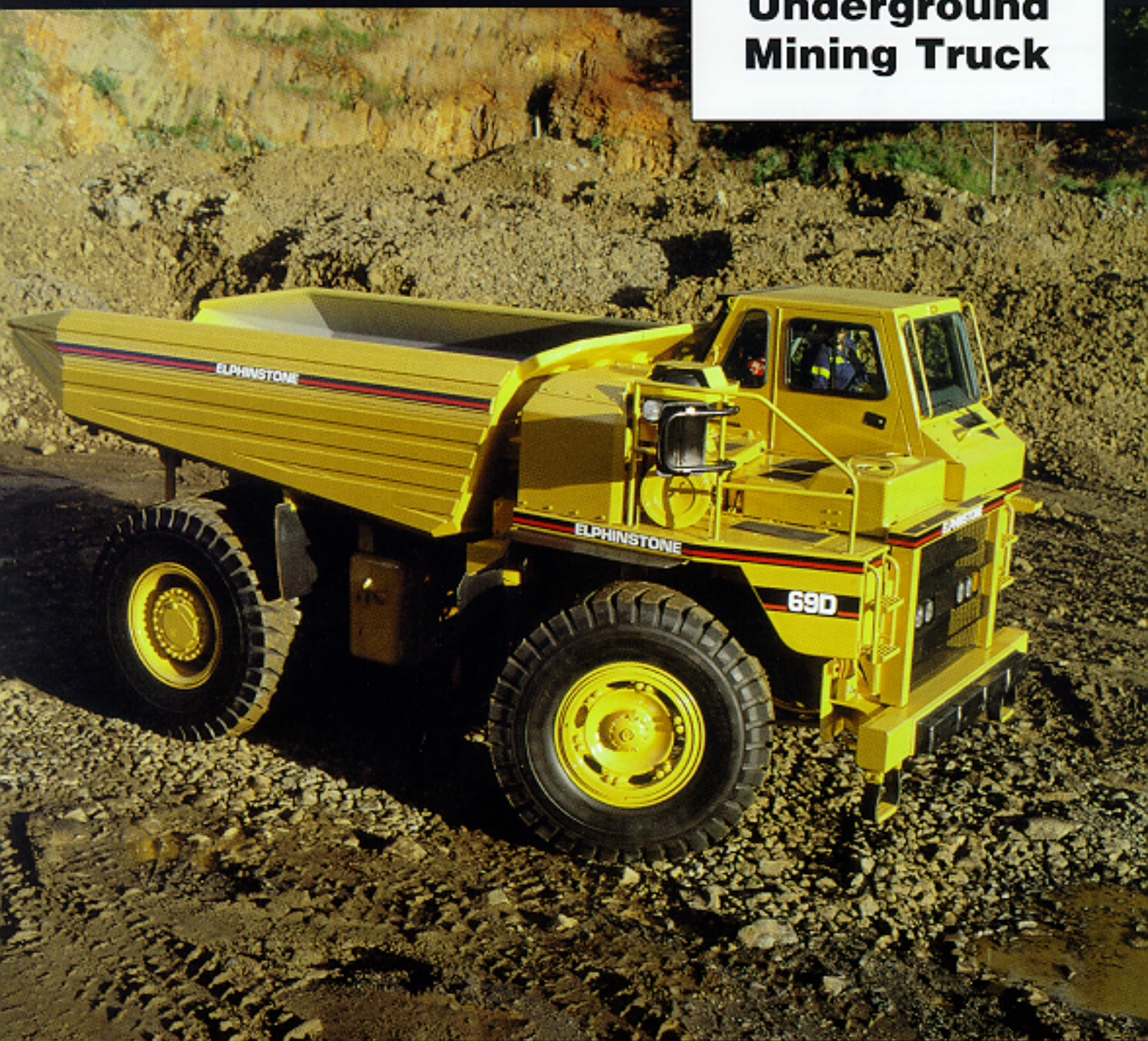

**CAT® 3408E HEUI Engine
Gross Power 380 kW (510HP)
Weight Empty 30100kgs (66371lbs)
Weight Loaded 68182kgs (150341lbs)**

Underground Mining Truck Dump Truck RIGID FRAME

Flywheel Power	380kW	(510HP)
Engine Model	3408E	HEUI
Weight Empty	30100kg's	(66,371lbs)
Weight (Loaded)	68182kg's	(150341lbs)
Distribution Loaded:		
Front	33%	
Rear	67%	
Max. Capacity, Tonnes	38.0	(42.0 T US)
Cubic Capacity (Standard Body)		
Heaped(2.1) (SAE)	18.3m ³	(23.9cu.yd.)
Width	3665mm	(144")
Height	3442mm	(135.5")
Length	8127mm	(319")
Turning Radius	9616mm	(379")
Loading Height (Empty)	3058mm	(120")
Speeds Forward		
1st	12.4	(7.7)
2nd	16.9	(10.5)
3rd	23.0	(14.3)
4th	30.9	(19.2)
5th	41.2	(25.6)
6th	54.2	(33.7)
7th	76.6	(47.6)
Speeds Reverse		
1st	13.5	(8.4)
Tyre Size 18.00 x 33.2 ** Radials		
Body Raise Time	11.0	Secs.
Ground Clearance	487mm	(19.2)
Body Height (Raised)	5735mm	(226)

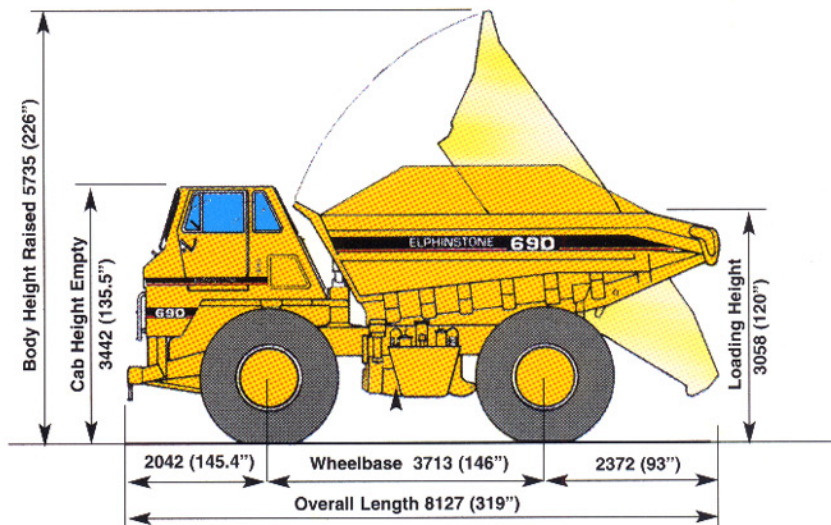
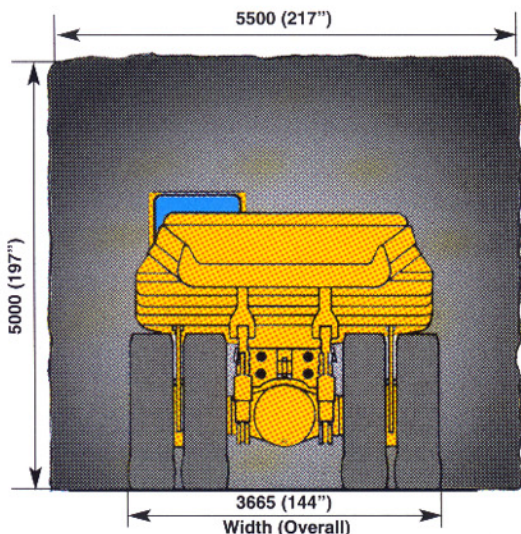
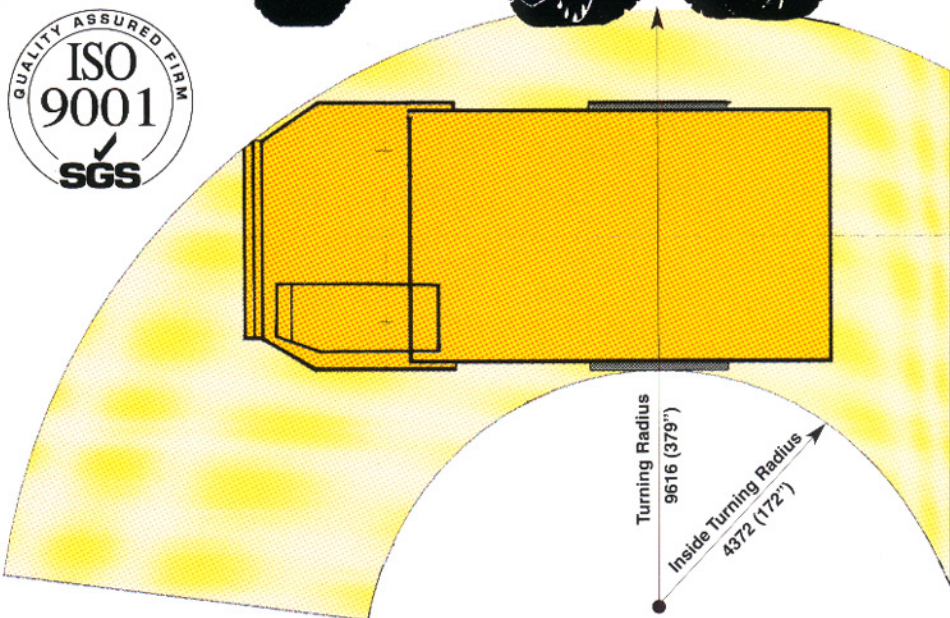

SUBJECT TO CHANGE WITHOUT NOTICE... COPYRIGHT.

ELPHINSTONE

CATERPILLAR ELPHINSTONE PTY. LTD.

For your requirements contact your Elphinstone Dealer or Caterpillar Elphinstone Pty. Ltd. Burnie, Tasmania, Australia.
Phone: (Int) 61 3 6431 2311 (Local) 03 6431 2311
Fax: (Int) 61 3 6431 7262 (Local) 03 6431 7262
Email: ceplinfo@cepl.com

AREA ELPHINSTONE DEALER



69D 7DE3628 - 02 UC LTR (1999)

Manufactured In Australia for World Export