

# EJC 115 LP

## TECHNICAL SPECIFICATION

***LARGE CAPACITY IN A LOW PROFILE  
CAPACITY: 5500 KG***

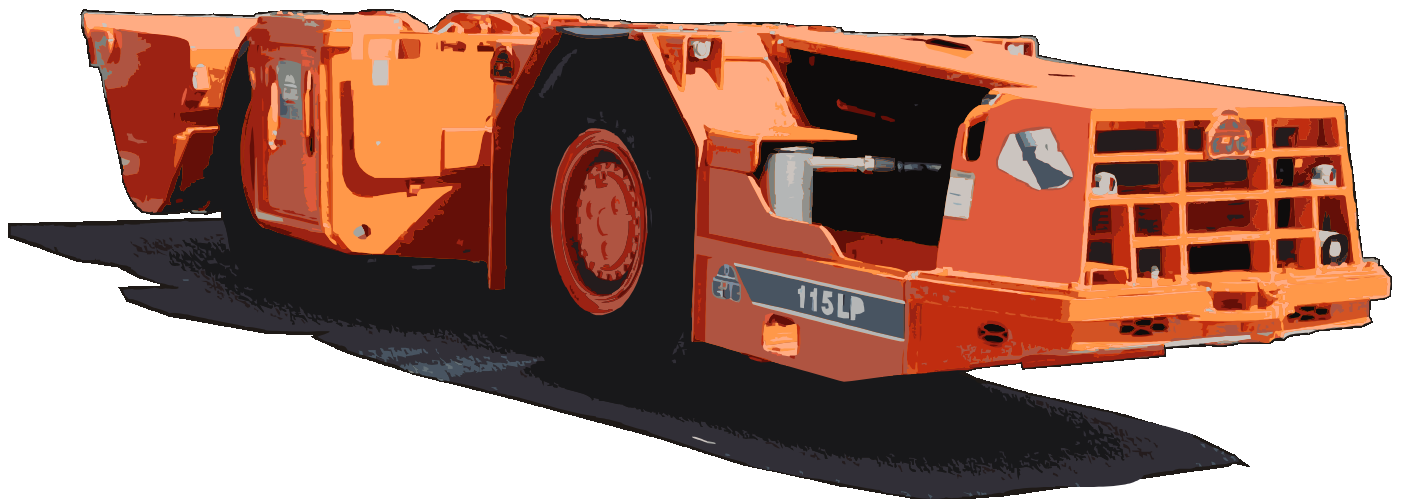

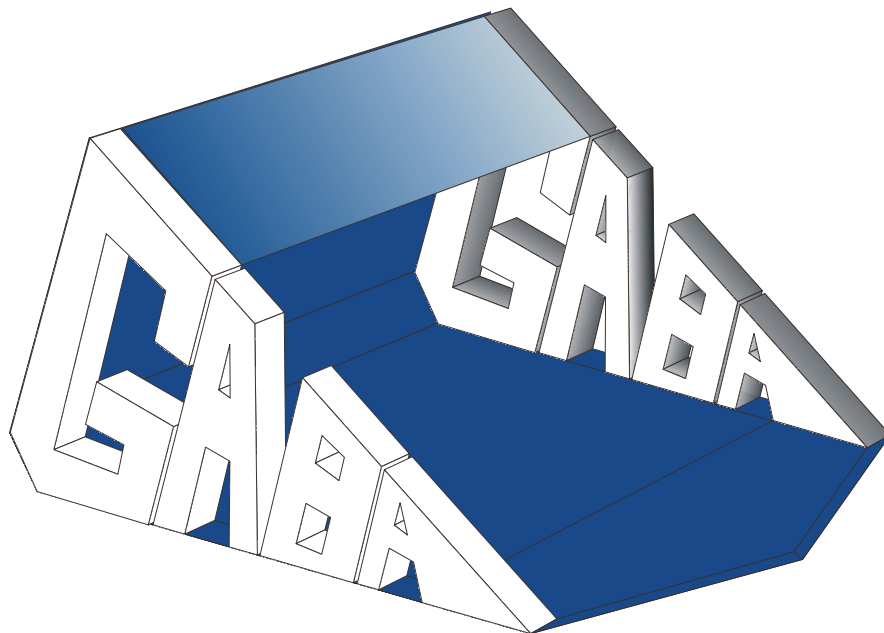

### Main Dimensions

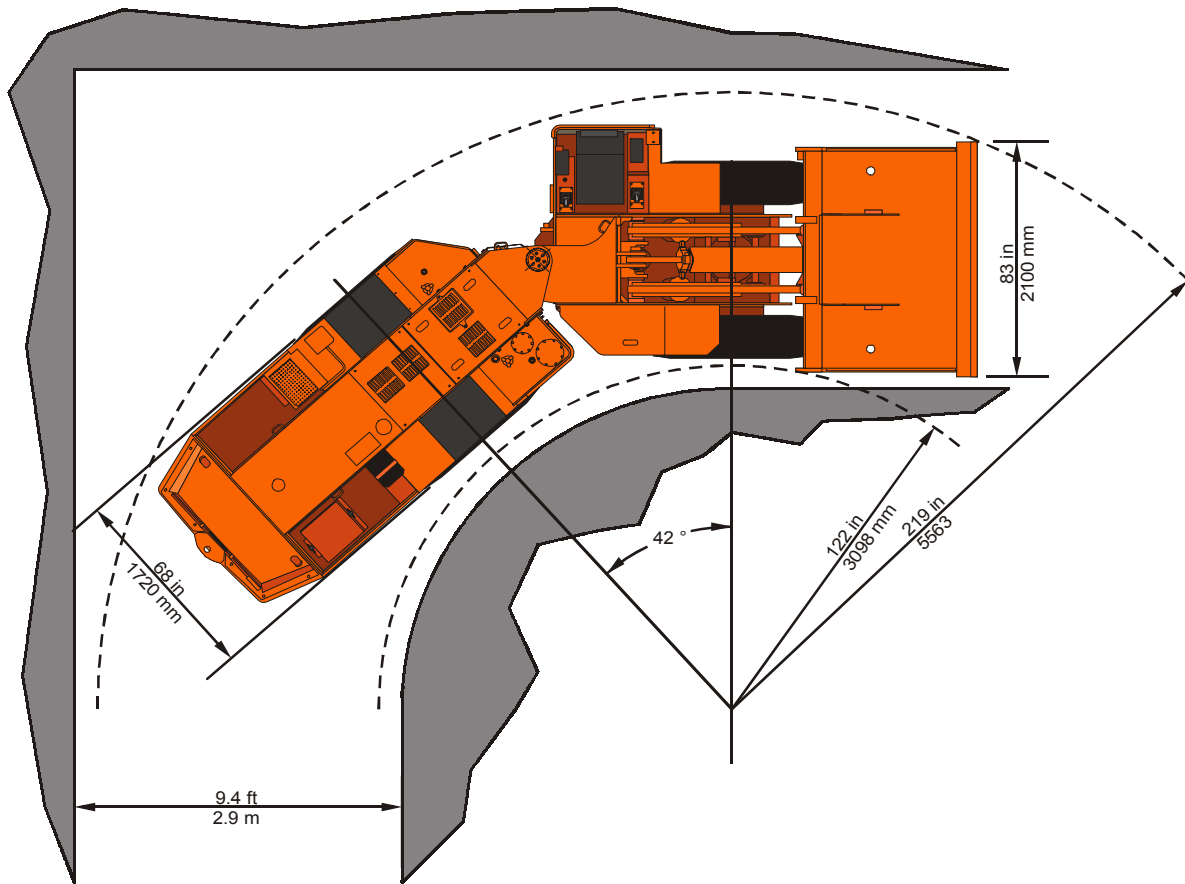
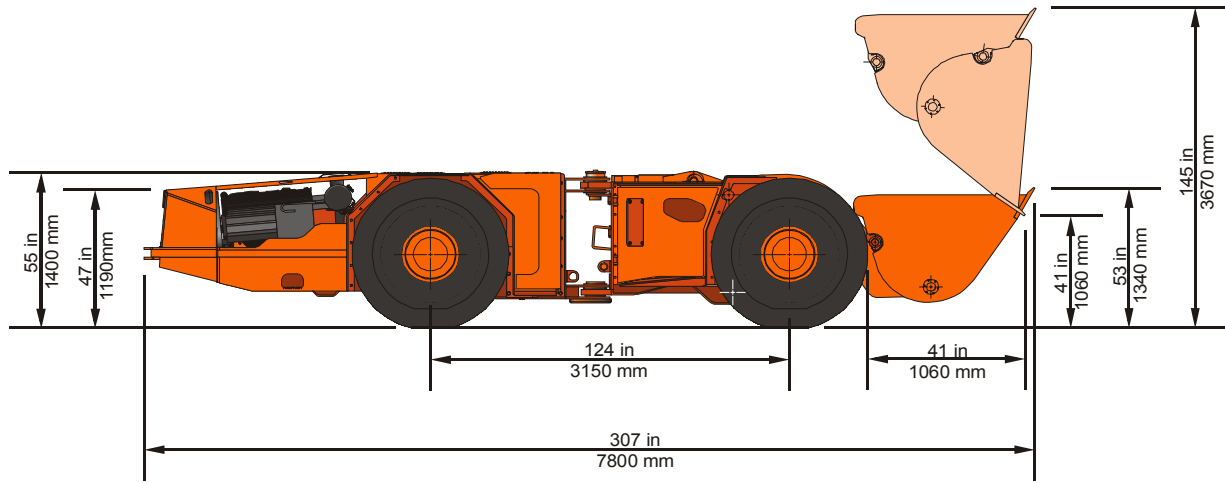



# Specification Sheet

**SANDVIK TAMROCK**  
**EJC Loaders Division**

CUSTOMER: \_\_\_\_\_  
 P.O. NBR. \_\_\_\_\_  
 SHIP DATE \_\_\_\_\_

**STANDARD UNIT**

Detroit Diesel D706LTE rated at 122 hp (91 kW)  
 Donaldson dry type air cleaner  
 ECS catalytic exhaust purifier with silencer  
 Clark modulated shift transmission  
 Clark torque converter  
 Clark axles with Posi-Stop brakes (incl. manual brake release)  
 14:00 x 24-20 PLY L5S tires  
 3.00 yd<sup>3</sup> (2.3m<sup>3</sup>) bucket with 500 BHN lip  
 Pilot operated single lever joystick bucket control  
 Pilot operated stick steer control  
 Hydraulic transmission shift  
 Central hydraulic pressure test points  
 Hydraulically controlled auto brake system  
 Halogen lights  
 Back-up alarm, audible  
 24-volt DC electrical system  
 Central manual lube  
 ORS type hose fittings  
 Four (4) English parts manuals  
 4 operator and 4 service manuals

**BASE UNIT PRICE**

A1 = no impact on delivery time; A2 = delivery time on request

**OPTIONAL EQUIPMENT**

- A2 \* Automatic lubrication system (Lincoln Modular)
- A2 \* Ejector bucket 3.0yd<sup>3</sup> (2.3 m<sup>3</sup>) 65" (1651mm) wide
- A1 FOPS canopy
- A1 Fire suppression system, Ansul 8 nozzle
- A1 Hand held fire extinguisher 10 lb.
- A1 Dual video cameras / monitor
- A1 Spare rim & tire, standard
- A1 Spare rim
- A1 Stitch welded tanks / skirts
- A1 Additional spare parts manuals
- A1 Additional workshop manuals

(\* Replaces the standard equipment





## Standard Unit

### Main dimensions

Total length	7 823 mm (308")
Maximum width	2273 mm (89.5")
Height without canopy	1400 mm (55")

### Weights

Operating weight	14 818 kg (32 600 lb.)
Total loaded weight	20 045 kg (44 600 lb.)

### Axle weights without load

front axle	6 328 kg (13 922 lb.)
rear axle	8488 kg (18 674 lb.)

### Axle weights with load

front axle	14 072 kg (30 958 lb.)
rear axle	6 200 kg (13 642 lb.)

### Capacities

Tramming capacity	5 455 kg (12 000 lb.)
Breakout force, lift	61.4 kN (13 800 lbf)
Breakout force, tilt	93 kN (20 900 lbf)
Tipping load	15 890 kg (35 000 lb.)
Standard Bucket	2.3 m <sup>3</sup> (3.0 yd <sup>3</sup> )

### Bucket motion times

Raising time	4.5 sec.
Lowering time	3.0 sec.
Dumping time	4.0 sec

### Driving speeds forward and reverse

1st gear	4.0 km/h (2.5 m.p.h.)
2nd gear	8.0 km/h (5.0 m.p.h.)
3rd gear	13.4 km/h (8.3 m.p.h.)
4th gear	21 km/h (13.1 m.p.h.)

### Frame

Rear and front frame	Welded steel box construction
Material	G40.21 - 50wt Cat.3
Central hinge	Welded steel box construction with hardened steel spherical bearings

Material

G40.21 - 50wt Cat.3

### Standard engine

Diesel engine	Detroit Diesel D706LTE
Output	91 kW (122 Hp) @ 2 300 rpm
Torque	470 Nm (347 lbf-ft) @ 1 400 rpm
Number of cylinders	6
Displacement	4.16 l (254.1 in <sup>3</sup> )
Cooling system	Liquid cooled
Combustion principle	Turbo charged, direct injected
Air filtration	Donaldson, dry type
Electric system	24 V
Exhaust purification	ECS catalytic purifier

### Standard converter

Clark C 272, single stage	Stall torque ratio: 2.87:1
	Offset Ratio: 1.042:1

### Transmission

Clark R32421	4-speed forward and reverse with modulation
--------------	---

### Standard axles

Front axle	Clark 14D2149, Posi-Torque differential, fixed.
Rear axle	Clark 14D2149, Posi-Torque differential, oscillating $\pm 5^\circ$ .

### Standard tires

Tire size	14:00 X 24, 20 PLY L5S
Type	Bridgestone
Air pressure, front	552 kPa (5.52 bar) (80 psi)
Air pressure, rear	552 kPa (5.52 bar) (80 psi)

### Steering hydraulics

Full hydraulic power steering, centre articulated with one double acting steer cylinder, open centre system with gear pump. Equipped with pilot operated control stick.

### Turning radius (with std bucket):

Right	inner	3 098 mm (122 ")
	outer	5 563 mm (219 ")
Turning angle		42o

### Main components in steering system:

Hydraulic pump	Gear pump
Control valve	Parker
Steering cylinders	EJC 125 mm bore x 70 mm rod

### Pressure settings:

Main relief	16.5 MPa (165 bar) (2 400 psi)
Port relief valves	15.2 MPa (152 bar) (2 200 psi)

### Bucket hydraulics

Full hydraulic open-centre system with one gear pump. Equipped with pilot operated joystick control lever.

### Main components:

Lift cylinders	EJC 160 mm bore x 90 mm rod
Dump Cylinder	EJC 160 mm bore x 90 mm rod
Hydraulic pump	Gear Pump
Control valve	Parker

### Pressure Settings:

Main relief	16.5 MPa (165 bar) (2 400 psi)
Bucket dump	6.9 MPa (69 bar) (1 000 psi)
Bucket roll back	18.3 MPa (183 bar) (2 650 psi)
Lift arms raise	18.3 MPa (183 bar) (2 650 psi)
Lift arms lower	6.9 MPa (69 bar) (1 000 psi)
Hydraulic oil tank capacity	Approx. 189 l (50 gal)

### Standard brakes

Service brakes are spring applied / hydraulically released, liquid cooled multi-disc brakes on all wheels. Service brakes also function as an emergency brake, when the emergency brake button is engaged.

### Main components in the brake system:

Pressure accumulators	Parker Hannifin piston type
Brake pedal valve	Mico
Charging valve	Mico

### Electrical equipment

Alternator	24 V 60 A, min.
Batteries	2 x 12 V, 950 CCA
Starter	5 kW, 24 V, Heavy Duty
Driving and working lights	3pcs front, 5pcs rear

### Standard manuals (customer)

3 pcs Spare parts manuals	English
3 Operators manual	English
3 Service manual	English

### Standard manuals (market area)

1 pcs Spare parts manuals	English
1 Operators manual	English
1 Service manual	English





### Speeds on Grade

