

Atlas Copco

6 Tonne Capacity Scooptram® LHD Atlas Copco Wagner Inc.

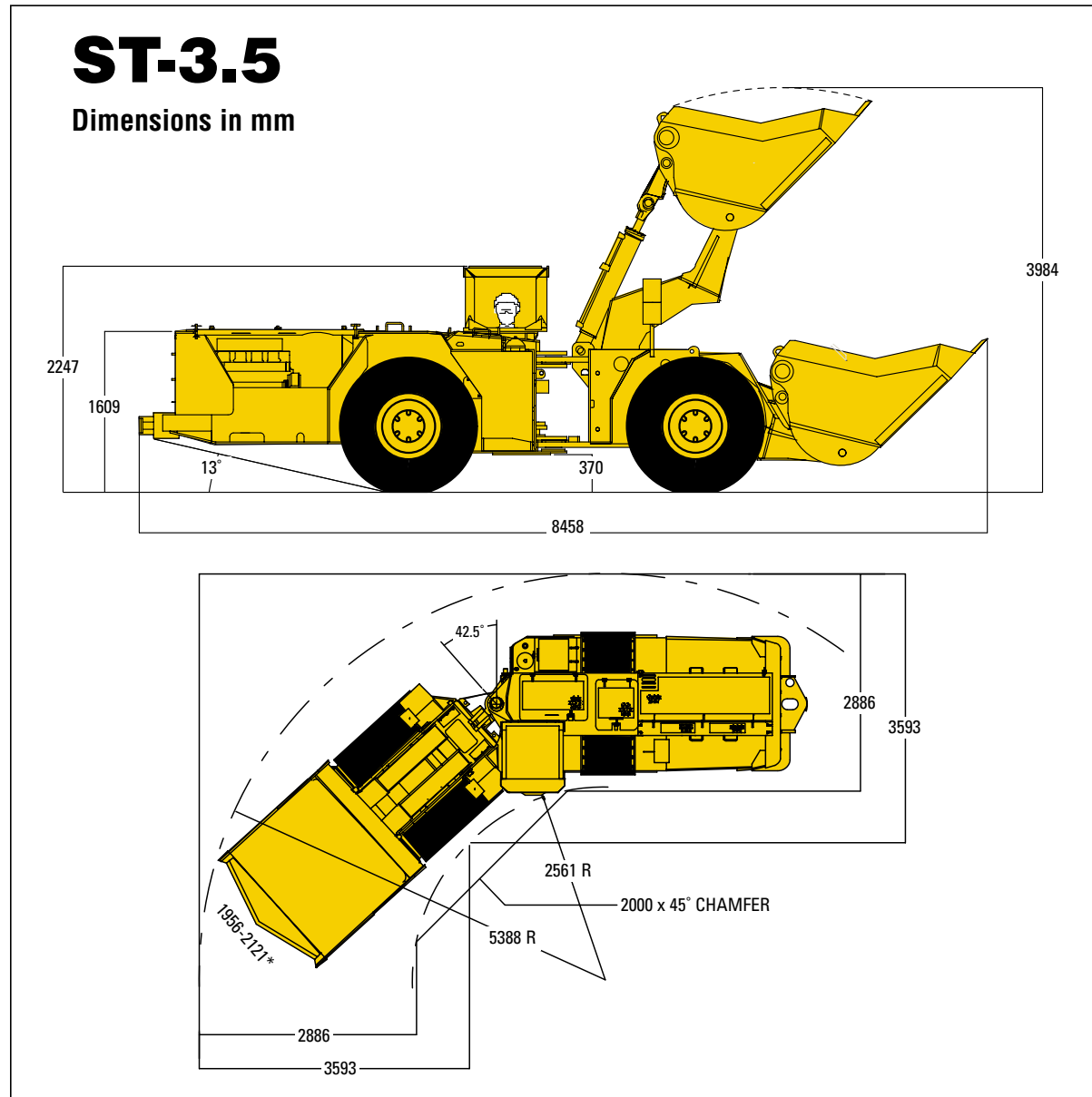

* Width depends on bucket volume sized to material density

Main Components

Canopy.....MSHA-ISO ROPS/FOPS Certified
 Bucket Volume.....3.1 m³ (Standard)
 Engine.....Deutz Diesel
 Axles.....Rock Tough®
 Brakes.....SAHR®



6 Tonne Capacity Scooptram® LHD

ST-3.5

Capacity

Tramming Capacity.....6000 kg (13,200 lbs)

Engine

Deutz Diesel.....F8L-413FW
136 kW (185 hp)

Exhaust System

Catalytic Purifier Plus Exhaust Silencer

Brakes

Service.....SAHR®

Spring Applied Hydraulically Released; Fully Enclosed,
Oil Cooled, Multiple Wet Discs at Each Wheel End

Parking and Emergency.....SAHR®

Tires

Tire Size, Front & Rear.....17.50 x 25, 20 Ply, L-5S

Operator's Arrangement

Side Seating for Bi-Directional Operation & Maximum Visibility,
MSHA-ISO ROPS/FOPS Certified Canopy

Operating Weight (Approximately)

Empty.....17510 kg (38,600 lbs)

Selected Options:

- E-O-D® Bucket
- Fire Suppression
- Auto Lube
- Radio Remote Control with Tow Hook
- Water Scrubber

© Copyright 2000 Atlas Copco Wagner Inc.
Scooptram, Rock Tough, E-O-D, and SAHR are registered trademarks of Atlas Copco Wagner Inc.
Atlas Copco is a registered trademark of Atlas Copco AB.
All rights reserved.