

BUCKET 3,0 M³ (WIDTH=2100)
BF 4 M1013 C

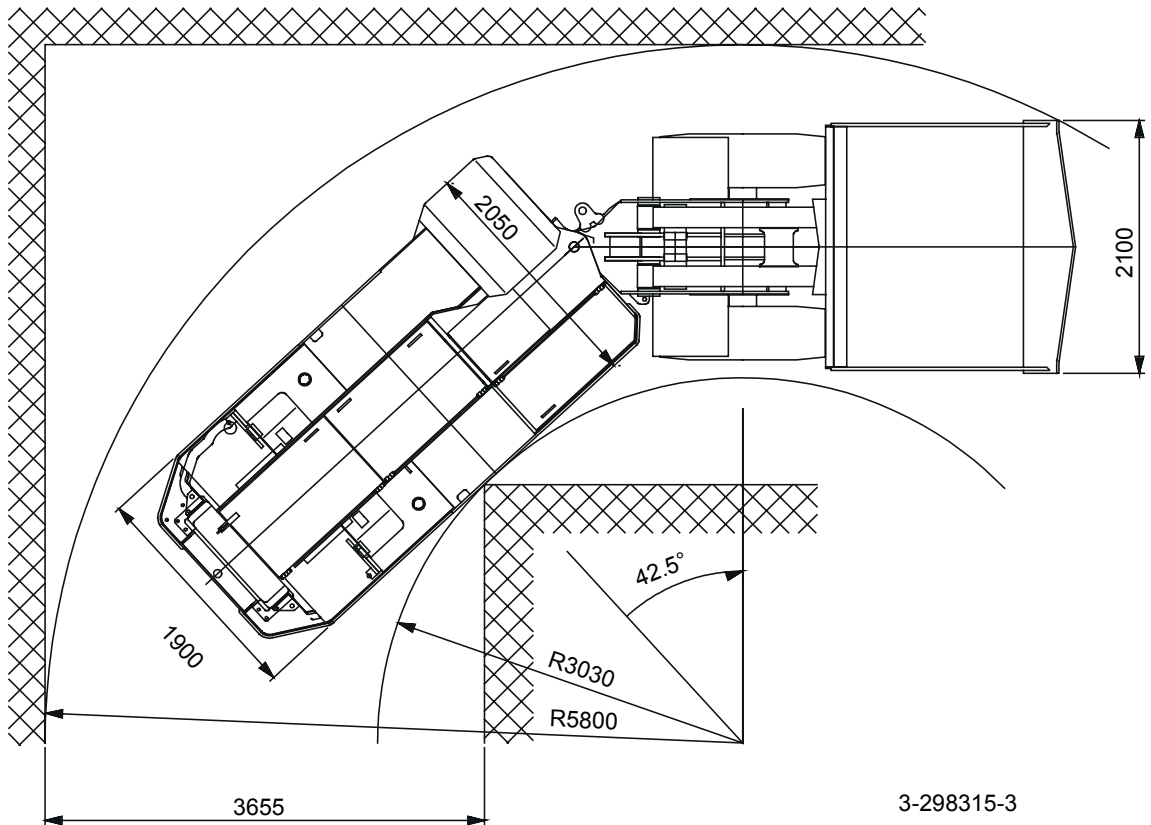
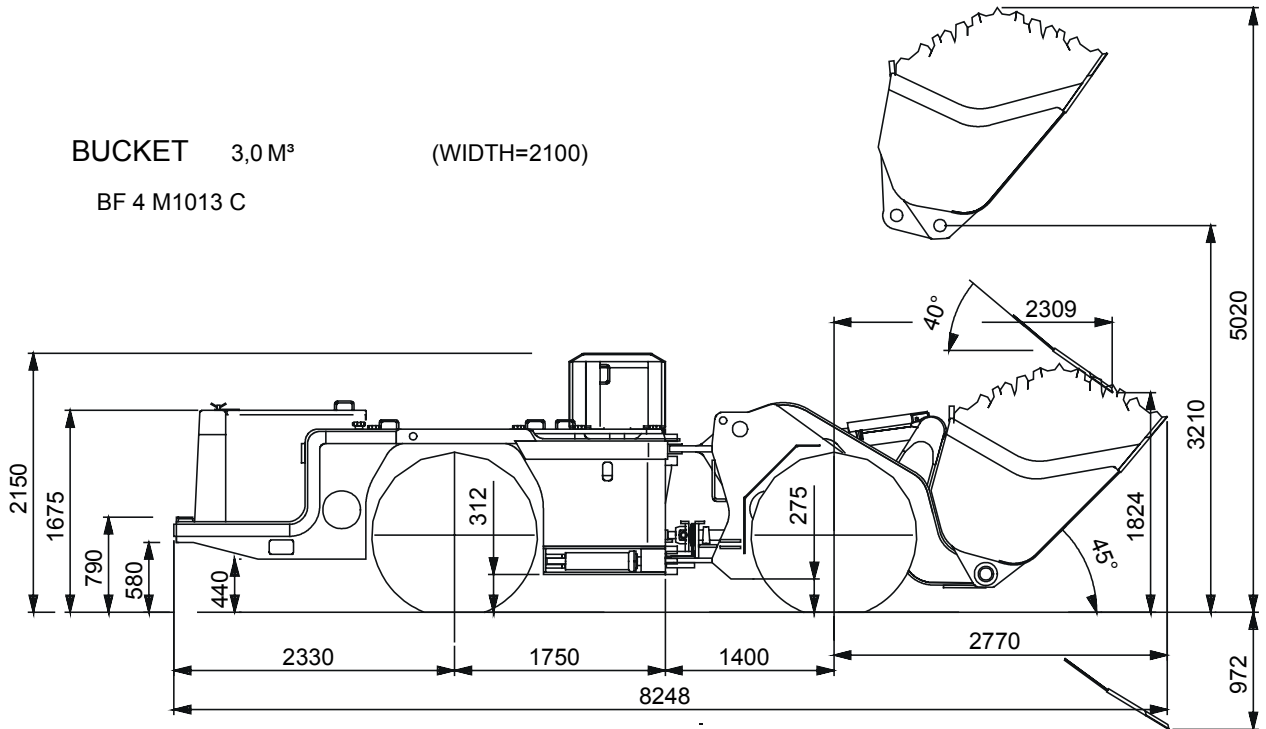

3-298315-3

Weights

Operating weight	16 600 kg (36 597 lb)
Total loaded weight	22 800 kg (50 266 lb)
Shipping weight	16 400 kg (36 156 lb)

Capacities

Tramming capacity	6200 kg (13 670 lb)
Breakout force, lift	130 kN (13 200 kg) (29 100 lb)
Breakout force, tilt	106 kN (10 900 kg) (24 022 lb)
Tipping load	12 600 kg (27 778 lb)
Bucket std.	3,0 m ³ (3.9yd ³), HB500/400

Bucket motion times

Raising time	6,7 sec.
Lowering time	3,9 sec.
Tipping time	2,0 sec.

Driving speeds forward and reverse

1st gear	5,0 km/h (3.1 mph)
2nd gear	10,0 km/h (6.2 mph)
3rd gear	25,0 km/h (15.5 mph)

Engine

Diesel engine	Deutz BF4M 1013C
Output	112 kW/2300 r/min (150 hp)
Torque	572 Nm 1400 r/min
Number of cylinders	in line 4
Displacement	4760 cm ³
Cooling system	Water cooled
Combustion principle	4-stroke/turbo, intercooler
Electric system	24V
Air filtering	Donaldson
Exhaust system	Catalytic purifier, muffler and exhaust pipe
Fuel tank capacity	180 l (47 gal.)

Drive line

Converter	Dana SOH, C 273
Gearbox	Dana SOH, R 28361
Axles	Front, Dana SOH, 16D Rear, Dana SOH, 16D, oscillating ± 10°.

Tyres

Size and type	17.5*25 L5S, Bridgestone
---------------	--------------------------

Operator compartment

Safety canopy.	
Height	2150 mm (85")
Width	2050 mm (81")

Lubrication system

Manual centralized lubrication
Optional automatic central lubrication

Manual languages

Spare part manual	
Operation instructions	main European languages
Maintenance instructions	main European languages
Engine spare part information	English
Machine spare part information	English
Workshop manual	
Operation instructions	main European languages
Maintenance instructions	main European languages
Engine workshop manual	Original
Power train components manual	Original
Optional equipment instructions	English

Optional bucket sizes

- Bucket size 2,7 m³ (3.5 yd³), width 1900 mm (75"), HB500/400.
- Bucket size 3,0 m³ (4.0yd³), width 1900 mm (75"), HB500/400.
- Bucket size 3,3 m³ (4.3yd³), width 2100 mm (83"), HB500/400.
- Ejector bucket, 3.0 m³ (4.0yd³), width 2100 mm (83"), HB500/400.