

Atlas Copco

28 Tonne Capacity Mine Truck Atlas Copco Wagner Inc.

MT-431B

Dimensions in mm

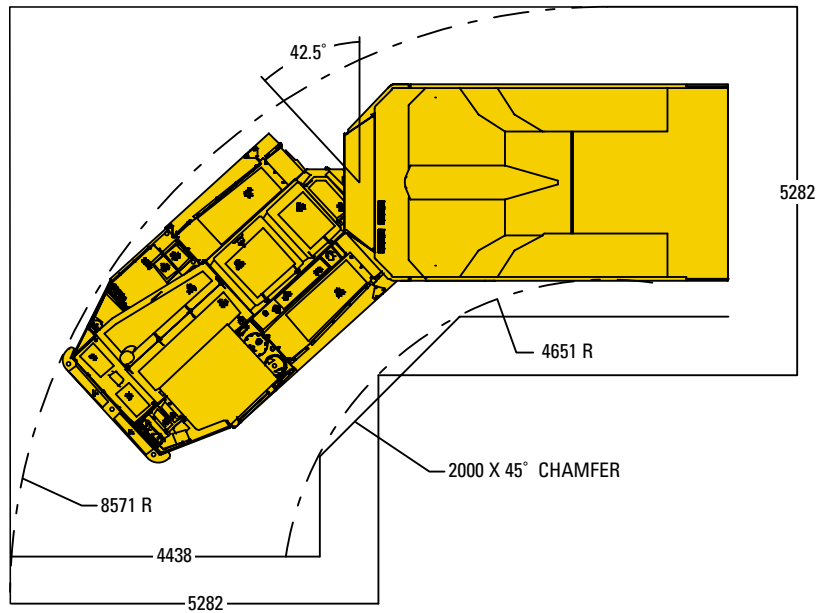
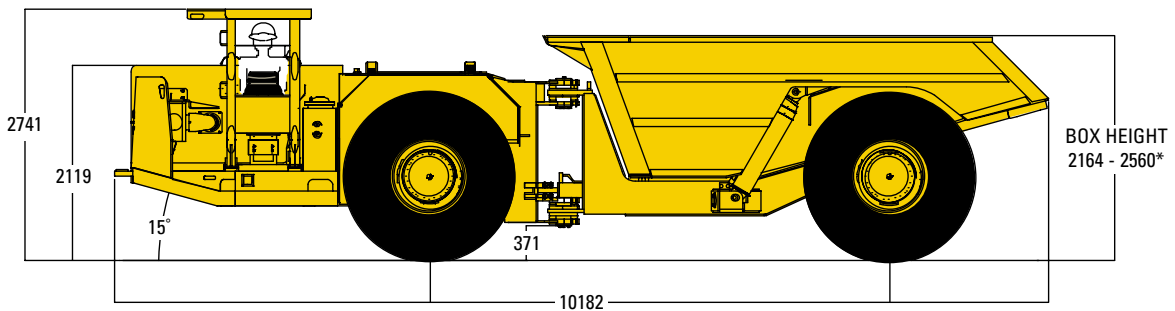

* Height depends on box volume sized to material density

Main Components

- Canopy.....MSHA-ISO ROPS/FOPS Certified
- Dump Box Volume (Semi-Heaped)..... 13.9 m³ (Standard)
- Engine.....Detroit Diesel
- Axles.....Rock Tough[®]
- Brakes.....SAHR[®]



Atlas Copco

28 Tonne Capacity Mine Truck

MT-431B

Capacity

Payload.....28123 kg (62,000 lbs)

Engine

Detroit Diesel.....Series 60 DDEC
278 kW (375 hp)

Exhaust System

Catalytic Purifier plus Exhaust Silencer

Brakes

Service.....SAHR®

Spring Applied Hydraulically Released; Fully Enclosed,
Force Cooled, Multiple Wet Discs at Each Wheel End

Parking and Emergency.....SAHR®

Tires

Tire Size, Front & Rear.....18.00R33, **E4

Operator's Arrangement

Side Seated Operator for Bi-Directional Operation & Maximum
Visibility and with MSHA-ISO ROPS/FOPS Certified Canopy

Operating Weight (Approximately)

Empty.....29270 kg (63,200 lbs)

Selected Options:

- Tele-Dump Box
- Fire Suppression
- Enclosed Cabin with Air Conditioning

© Copyright 2000 Atlas Copco Wagner Inc.
Scooptram, Rock Tough and SAHR are registered trademarks of Atlas Copco Wagner Inc.
Atlas Copco is a registered trademark of Atlas Copco AB.
All rights reserved.