

# Atlas Copco

## 6.5 Tonne Capacity Scooptram® LHD Atlas Copco Wagner Inc.

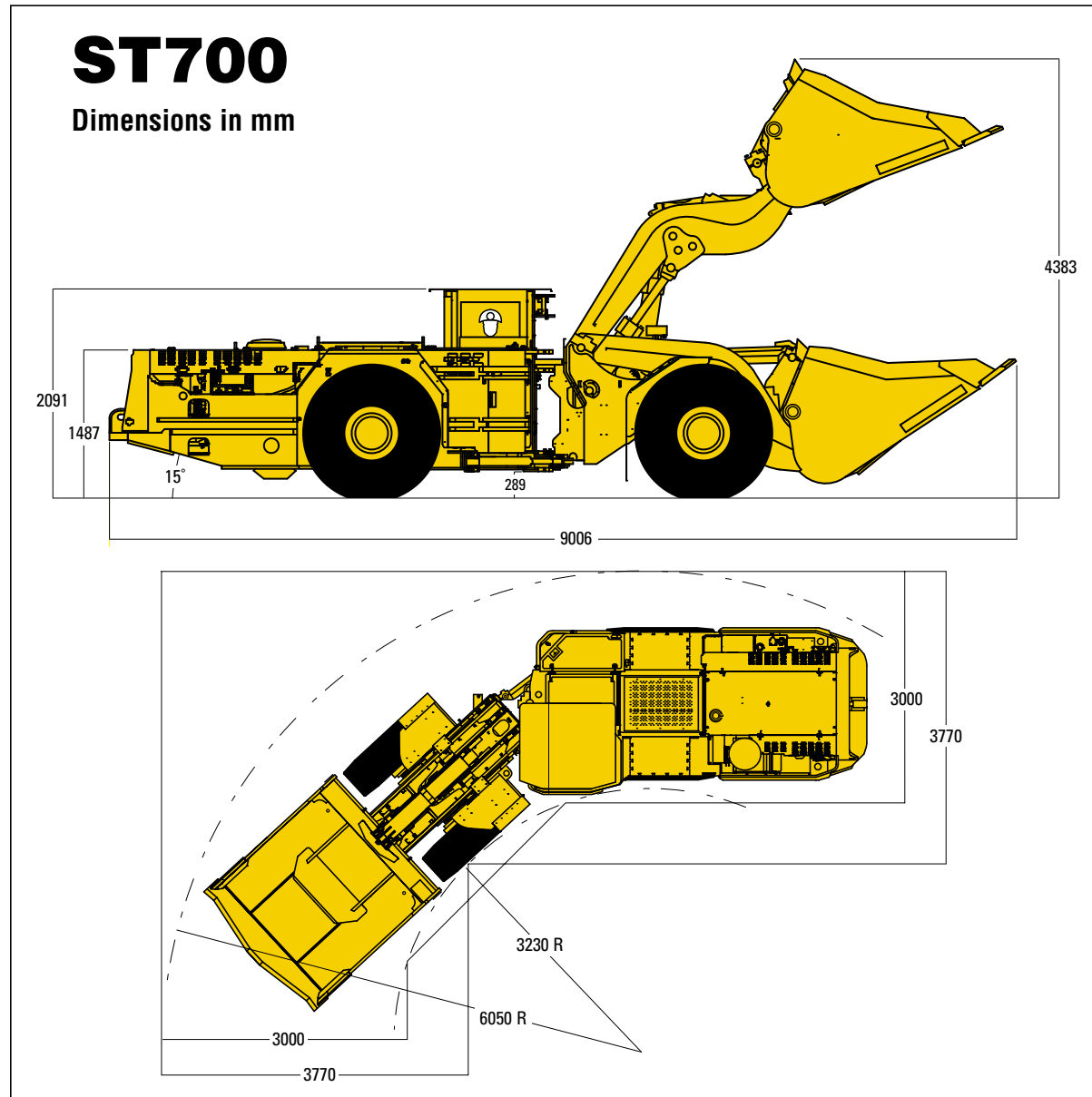

### Main Components

- Canopy.....MSHA-ISO FOPS Certified
- Bucket Volume.....25.3 m<sup>3</sup> (Standard)
- Engine.....Detroit Diesel
- Axles.....Rock Tough®
- Brakes.....SAHR®



## 6.5 Tonne Capacity Scooptram® LHD

### **ST700**

#### **Capacity**

Bucket Volume.....6500 kg (14,332 lbs)

#### **Engine**

Deutz Diesel

Detroit Diesel

#### **Exhaust System**

Catalytic Purifier Plus Exhaust Silencer

#### **Brakes**

Service.....SAHR®

Spring Applied Hydraulically Released; Fully Enclosed,  
Oil Cooled, Multiple Wet Discs at Each Wheel End

Parking and Emergency.....SAHR®

#### **Tires**

Tire Size, Front & Rear.....17.50 x 25, 20 Ply, L-5S

#### **Operator's Arrangement**

Side Seating for Bi-Directional Operation & Maximum Visibility,  
MSHA-ISO FOPS Certified Canopy

#### **Operating Weight (Approximately)**

Empty.....17000-18500 kg (37,500-40,000 lbs)

#### **Selected Options:**

Enclosed Cabin

Radio Remote Control

E-O-D® Buckets

Fire Suppression

© Copyright 2000 Atlas Copco Wagner Inc.  
Scooptram, Rock Tough, E-O-D, and SAHR are registered trademarks of Atlas Copco Wagner Inc.  
Atlas Copco is a registered trademark of Atlas Copco AB.  
All rights reserved.