

Atlas Copco

Technical Specifications

14.5 Tonne Capacity Scooptram® LHD Atlas Copco Wagner Inc.

ST-8C

Dimensions in mm

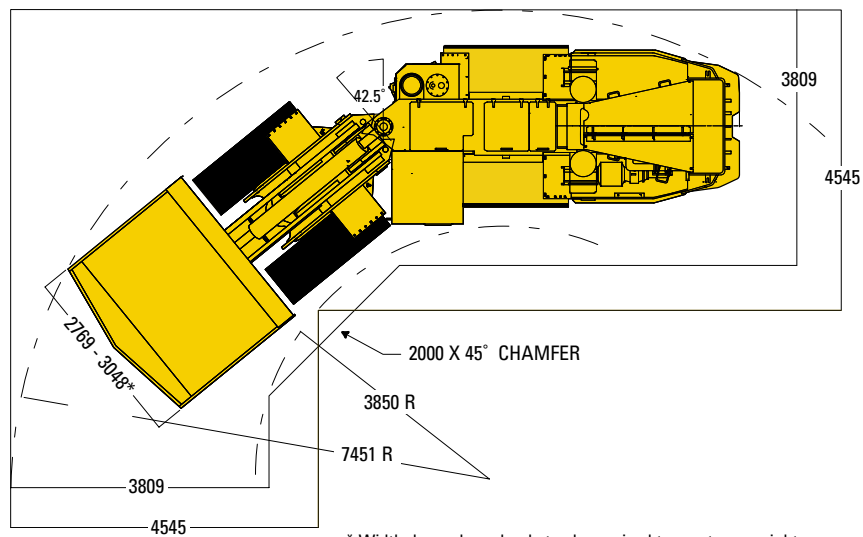
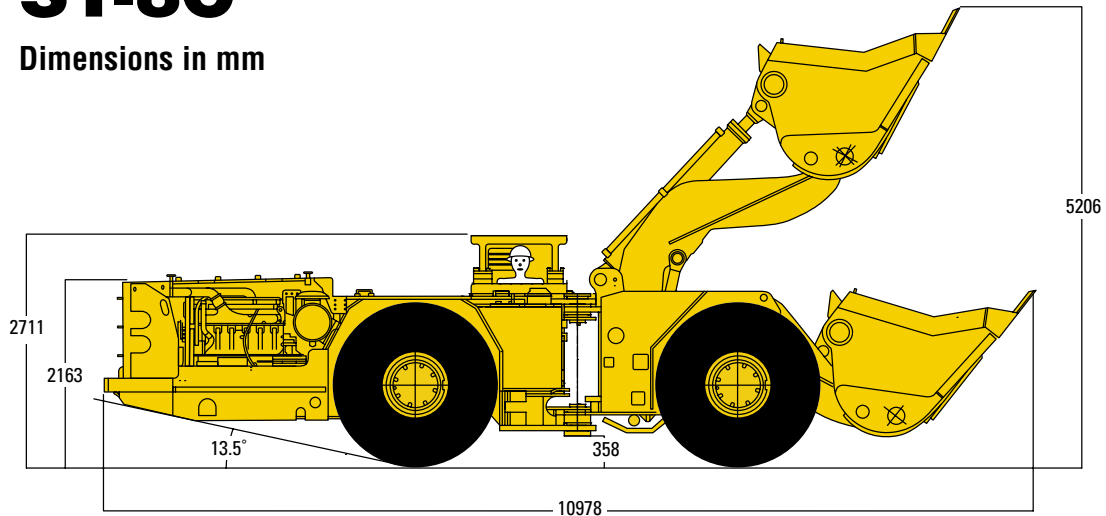

* Width depends on bucket volume sized to meet ore weight

Main Components

Canopy.....MHSA-ISO ROPS/FOPS Certified
Bucket Volume.....6.9 m³ (Standard)
Engine.....Detroit Diesel
Axles.....Spicer
Brakes.....SAHR®

Atlas Copco

14.5 Tonne Capacity Scooptram® LHD

ST-8C

Capacity

Tramming Capacity.....14500 kg (32,000 lbs)

Engine

Detroit Diesel.....Series 60 DDEC
242 kW (325 hp)

Exhaust System

Catalytic Purifier Plus Exhaust Silencer

Brakes

Service.....SAHR®

Spring Applied Hydraulically Released; Fully Enclosed,
Force Cooled, Multiple Wet Discs at Each Wheel End

Parking and Emergency.....SAHR®

Tires

Tire Size, Front & Rear.....29.5 x 25, 34 Ply, L-5S

Operator's Arrangement

Side Seated Operator for Bi-Directional Operation & Maximum
Visibility and with Canopy, MSHA-ISO ROPS/FOPS Certified

Operating Weight (Approximately)

Empty.....40680 kg (89,500 lbs)

Selected Options:

- Water Scrubber
- E-O-D® Bucket
- Fire Suppression
- Auto Lube
- Enclosed Cabin with Air Conditioning
- Radio Remote Control